

DIM

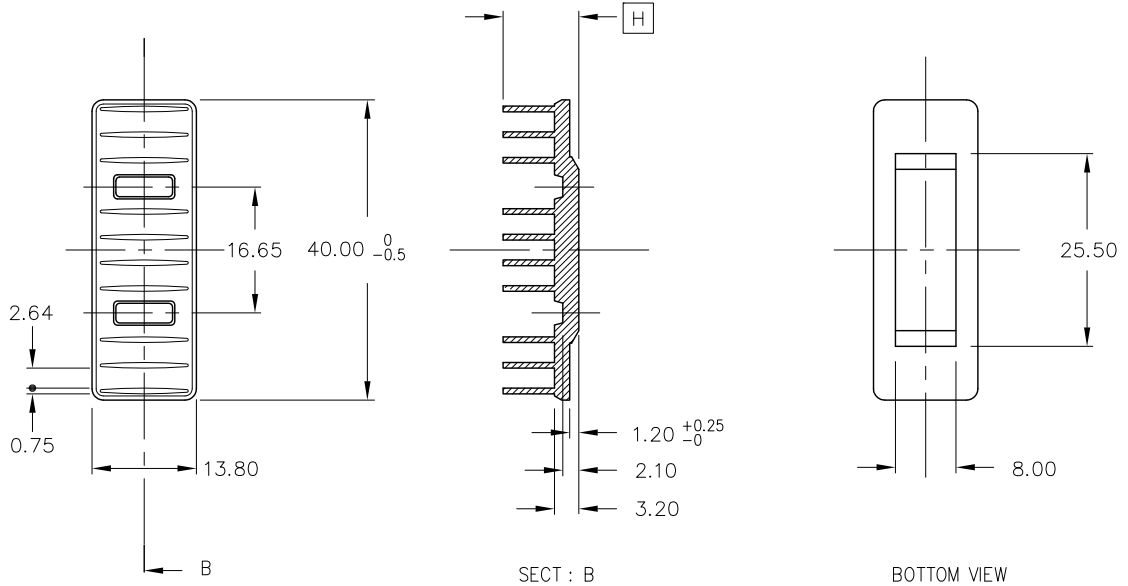

HEAT SINK  
 MATERIAL : A 6063  
 FINISH : BLACK ANODIZE

MODEL	HEIGHT [H]	WEIGHT (grams)
SFPM-5.2B	5.20	3.8
SFPM-10B	10.00	4.7
SFPM-13.5B	13.50	5.3

Dimensions : mm