

REVISIONS				
REV	DATE	DESCRIPTION	CHG	APPR

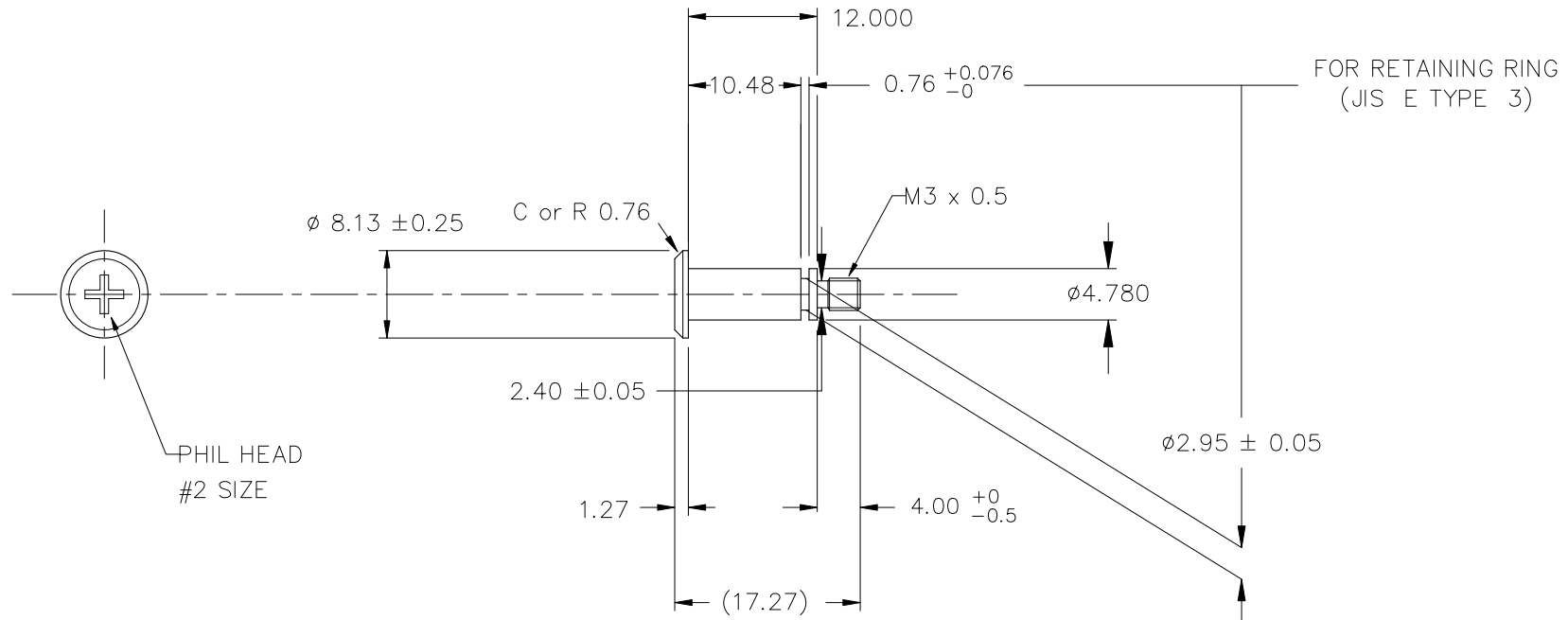

NOTES : UNLESS OTHERWISE SPECIFIED

1. INTERPRET DIMENSIONS AND TOLERANCES PER ANSI Y14.5M

2. ALL DIMENSIONS ARE IN MILLIMETERS.

3. MATERIAL

CARBON STEEL SWCH12A or EQUIVALENT
ZINC /CLEAR CHROMATE (Cr3+)

4. TOLERANCES : .XX ± 0.254
.XXX ± 0.127

5. REMOVE ALL BURRS AND BREAK SHARP EDGES.

6. UNSPECIFIED CORNER R0.5 MAX OR C0.5 MAX

7. MACHINED SURFACE FINISH TO BE $\frac{6.3}{\nabla}$ OR BETTER.

ITEM	PART NO.	PART NAME	REMARK	Q'TY
ALPHA CO.,LTD.			CSTMR'S PART NO.	
		MATERIAL NOTE 3	NAME SS-12-4.8-M3-4	
SCALE 2 : 1	APPR & CHCK M.YAMAMOTO	PART NO. & DWG NO. S089HX2E	REV	
DATE APR 19. 2021	DSGN & DWG M.YAMAMOTO	RDCTN:	LOFF:	

A3