

REVISIONS				
REV	DATE	DESCRIPTION	CHG	APPR
/	JUL. 13, '17	REMOVE DIMENSION OF UNDERCUTS-LENGTH FOR THREAD(WAS 1.00)	A. K.	A. K.

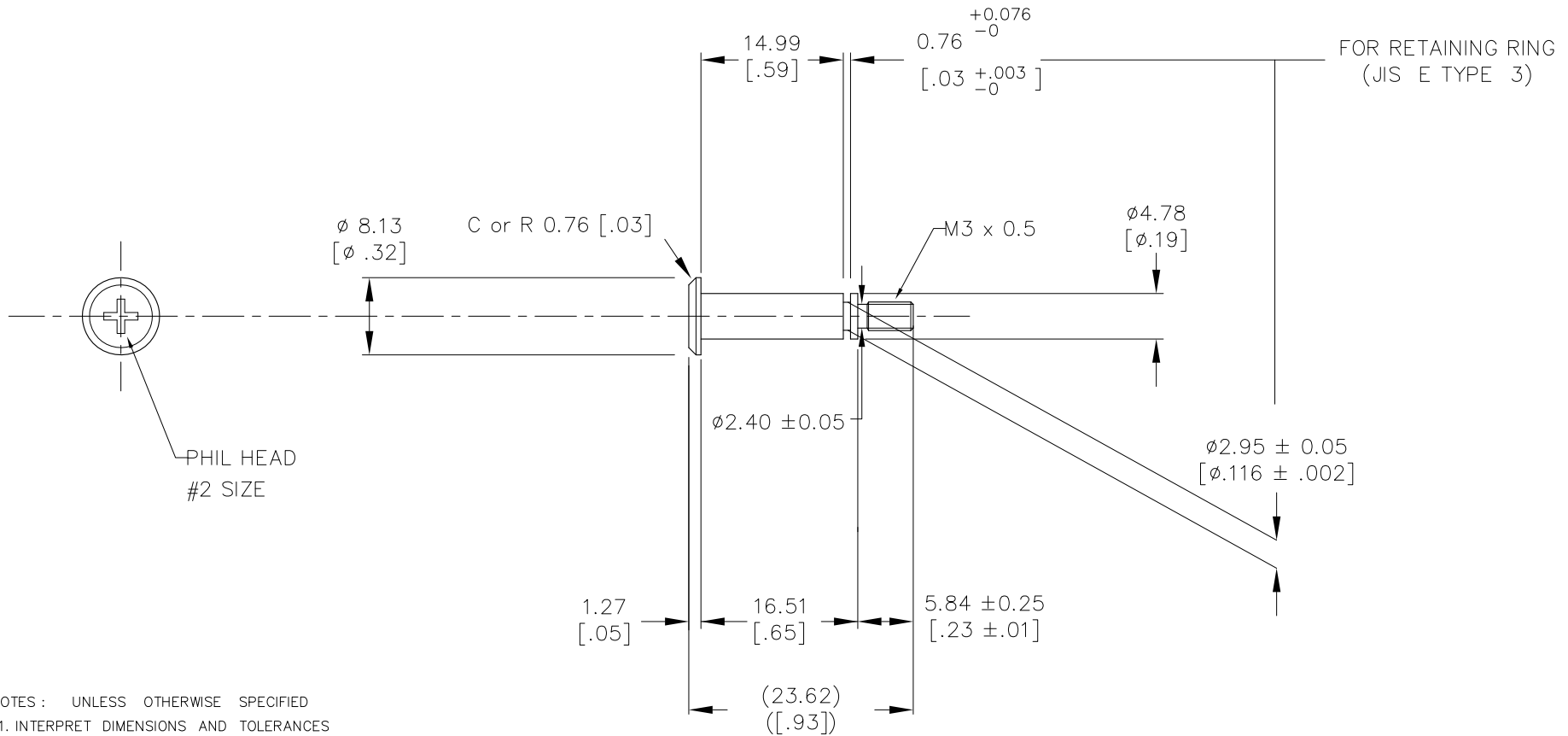

- NOTES : UNLESS OTHERWISE SPECIFIED
1. INTERPRET DIMENSIONS AND TOLERANCES PER ANSI Y14.5M-1
 2. ALL DIMENSIONS ARE IN MILLIMETERS.
 3. MATERIAL
CARBON STEEL SWCH12A or EQUIVAIENT
ZINC /CLEAR CHROMATE (Cr3+)
 4. TOLERANCES :
.X ±0.254
.XX ±0.127
 6. BREAK AND DEBUR ALL SHARP EDGES
 7. UNSPECIFIED RADII: 0.5 MAX
 8. MACHINED SURFACE FINISH TO BE $\sqrt{6.3}$ OR BETTER.

ITEM	PART NO.	PART NAME	REMARK	Q'TY
ALPHA CO.,LTD.			CSTM'R'S PART NO.	
	MATERIAL NOTE 3		NAME SS-16.5-4.8-M3-5.8	
SCALE 2 : 1	APPR & CHCK M.YAMAMOTO		PART NO. & DWG NO. S089HX1W	
DATE JAN 06 2016	DSGN & DWG M.YAMAMOTO		RDCTN:	LOFF: