

REVISIONS				
REV	DATE	DESCRIPTION	CHG	APPR
PRODUCTION RELEASE				

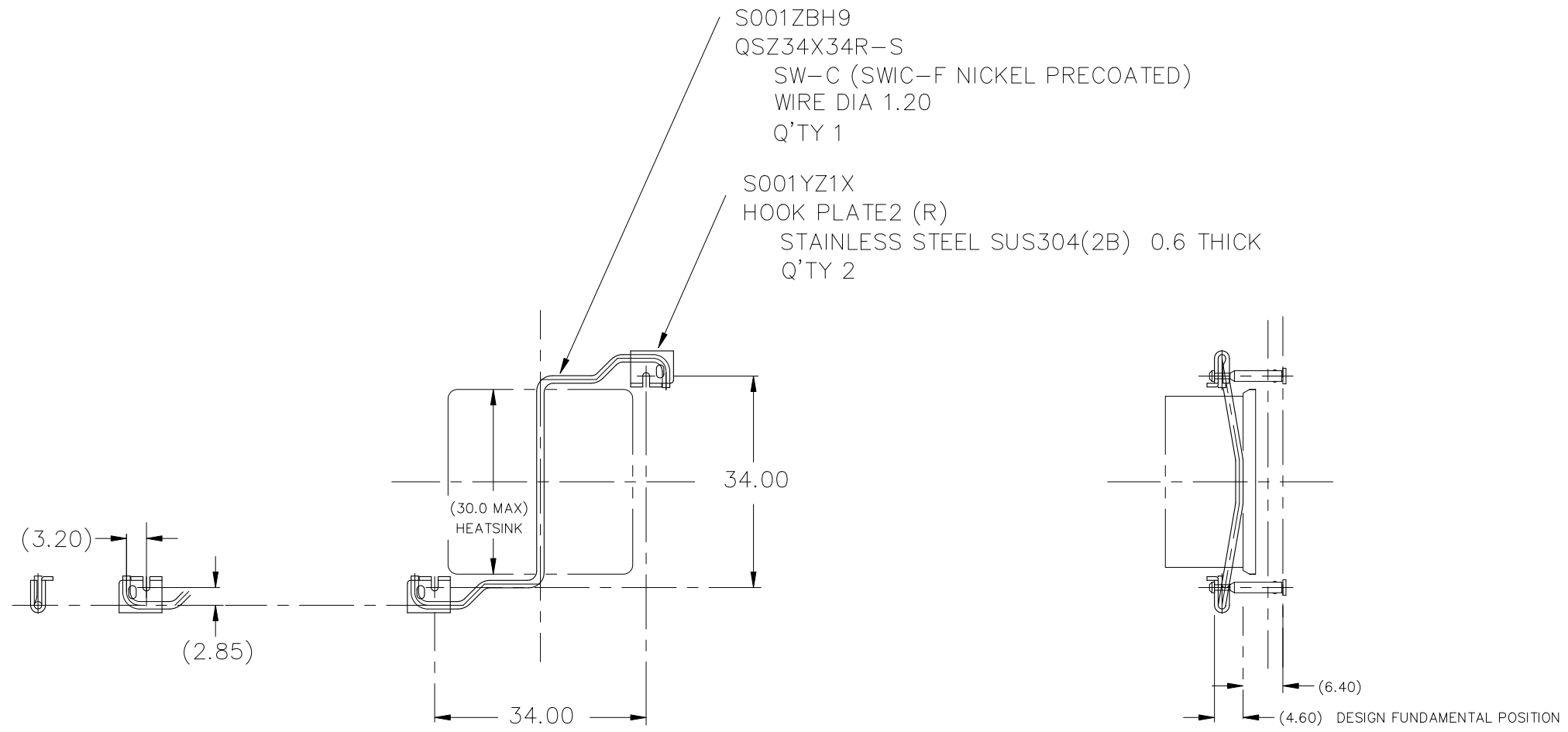

ANCHOR LAYOUT ON BOARD  
REQUIRES  $\phi 1.80 \pm 0.05$  THRU HOLES  
FOR ANCHORS IN BOARD.

- NOTES : UNLESS OTHERWISE SPECIFIED
1. INTERPRET DIMENSIONS AND TOLERANCES PER ANSI Y14.5M
  2. ALL DIMENSIONS ARE IN MILLIMETERS.
  3. TOLERANCES :  
 .XX  $\pm 0.254$   
 .XXX  $\pm 0.127$   
 ANGLES  $\pm 3^\circ$

ITEM	PART NO.	PART NAME	REMARK	Q'TY
<b>ALPHA CO.,LTD.</b>			CSTM'R'S PART NO.	
		MATERIAL	NAME	QSZ34X34R
SCALE		APPR & CHCK	PART NO. & DWG NO.	REV
1 : 1		Y.SUZUKI	S001ZBH8	
DATE		DSGN & DWG	RDCTN:	LOFF:
APR 10 2018		Y.SUZUKI		

A3