

REVISIONS				
REV	DATE	DESCRIPTION	CHG	APPR
/	JUL 13, '21	CHG S089JK1S QTY (WAS 4) CHG SHEETMETAL THK (WAS 2.28)	M.Y.	M.Y.

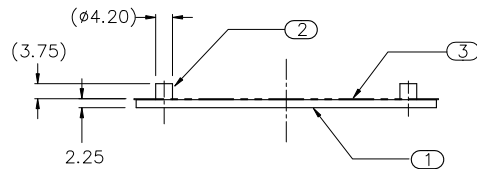
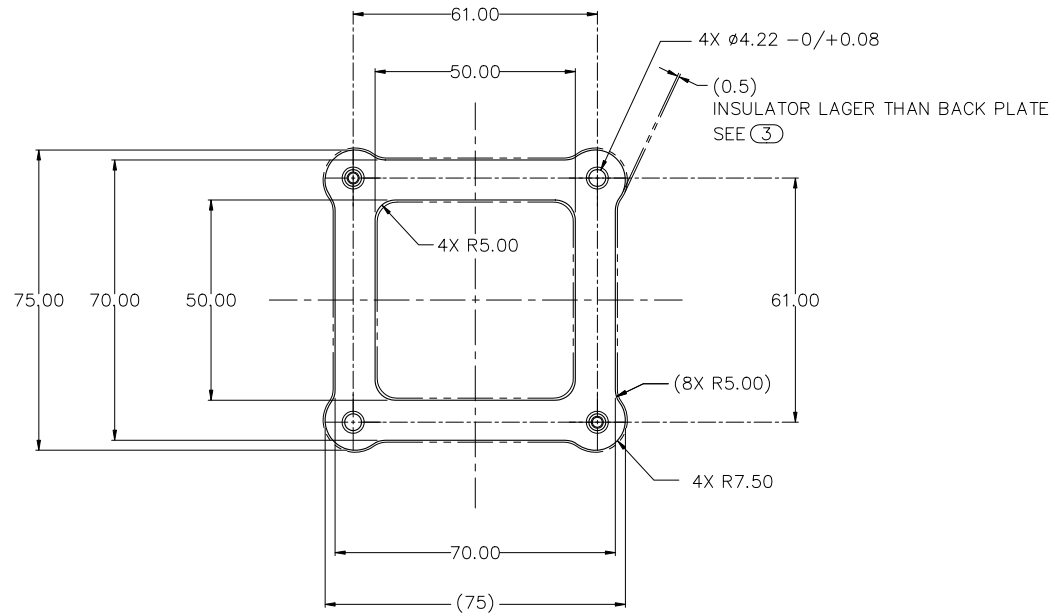

- NOTES : UNLESS OTHERWISE SPECIFIED
1. INTERPRET DIMENSIONS AND TOLERANCES PER ANSI Y14.5M
 2. ALL DIMENSIONS ARE IN MILLIMETERS.
 3. TOLERANCES : ± 0.254

(3)	S001YZ6D	<INSULATOR> INS-70	POLYCARBONATE FILM PLUS ACRYLIC ADHESIVE APPLIED TO ONE SIDE THICKNESS 0.25	1
(2)	S089JK1S	<STANDOFF> PEM S0-M3-6ZI	STANDOFF M3 THRU (PEM S0-M3-6ZI OR EQUIVALENT)	2
(1)	S001YZ6C	<BACK PLATE> BPL-70-BLK	STEEL SPCC -JIS G3141 or ASTM A1008 THICKNESS 2.00 ELECTRIC NICKEL PLATING	1
ITEM	PART NO.	PART NAME	REMARK	Q'TY
ALPHA CO.,LTD.			CSTM'R'S PART NO.	
		MATERIAL	NAME BPL-70	
SCALE 1 : 1		APPR & CHCK T. SUZUKI	PART NO. & DWG NO.	REV
DATE MAY 17, 2021		DSGN & DWG T. SUZUKI	S001YZ6B	
RDCTN:			LOFF:	