

- NOTES : UNLESS OTHERWISE SPECIFIED
1. INTERPRET DIMENSIONS AND TOLERANCES PER ANSI Y14.5M
  2. ALL DIMENSIONS ARE IN MILLIMETERS.
  3. MATERIAL SW-C (SWIC-F NICKEL PRECOATED)  
WIRE DIA 1.40
  4. TOLERANCES :  
.XX ±0.254  
.XXX ±0.127  
ANGLES ± 3°
  5. INNER CORNER RADIUS 1.5

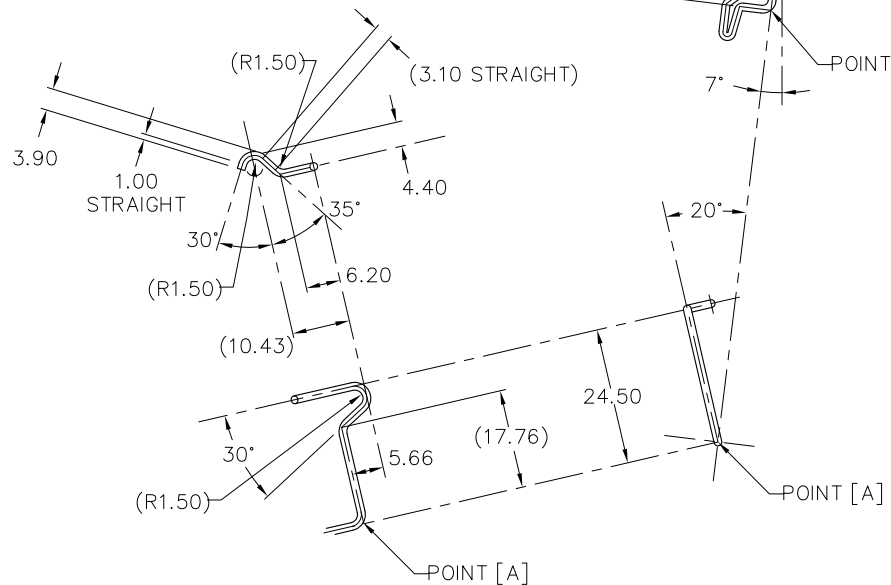

REVISIONS				
REV	DATE	DESCRIPTION	CHG	APPR

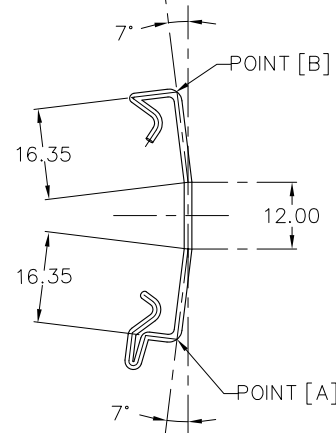
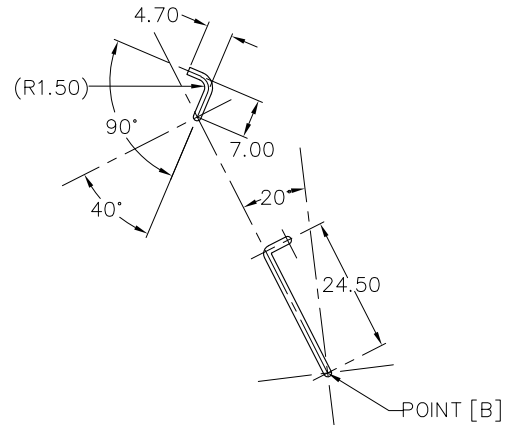
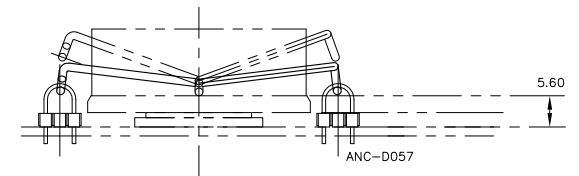
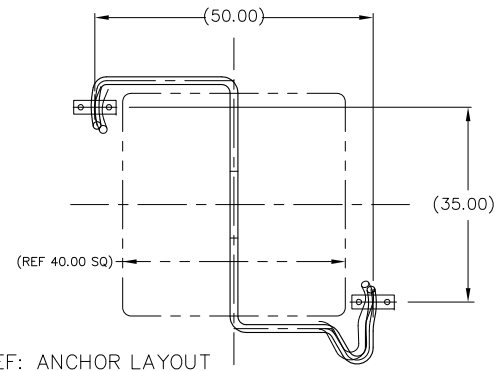

ITEM	PART NO.	PART NAME	REMARK	Q'TY
ALPHA CO.,LTD.			CSTM'R'S PART NO.	
MATERIAL SEE NOTE 3		NAME EZL-50x35		
SCALE 1 : 1		APPR & CHCK Y.SUZUKI	PART NO. & DWG NO. S001ZBG4	REV
DATE MAR 02 2017		DSGN & DWG Y.SUZUKI	RDCTN:	LOFF: