

REVISIONS				
REV	DATE	DESCRIPTION	CHG	APPR
PRODUCTION RELEASE				

S001YZ1Y
HOOK PLATE2(L)
STAINLESS STEEL SUS304(2B) 0.6 THICK
Q'TY 2

S001ZB7L
QSZ49x49-S
SW-C (SWIC-F NICKEL PRECOATED)
WIRE DIA 1.40
Q'TY 1

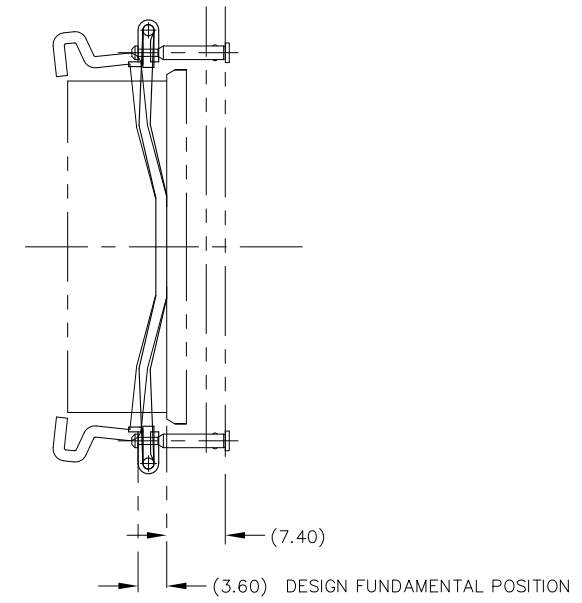
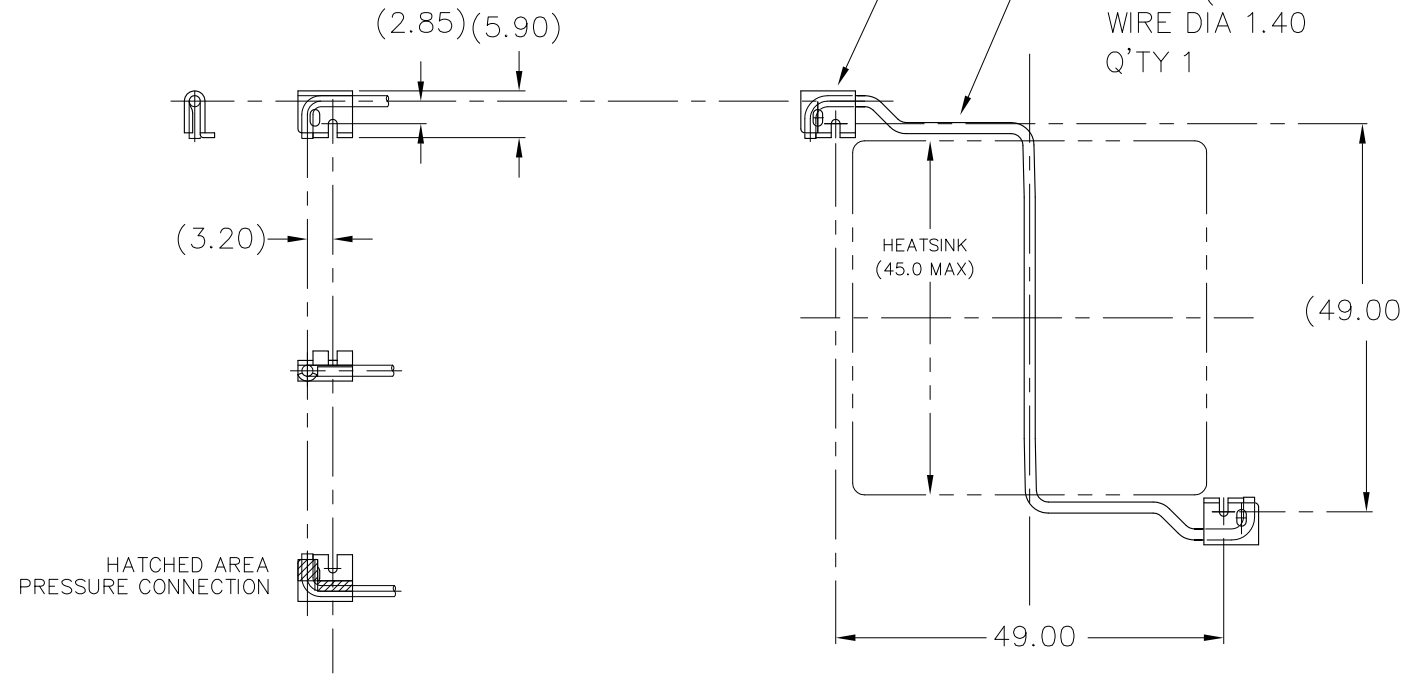

ANCHOR LAYOUT ON BOARD
REQUIRES $\phi 1.80 \pm 0.05$ THRU HOLE
FOR ANCHORS IN BOARD.

- NOTES : UNLESS OTHERWISE SPECIFIED
1. INTERPRET DIMENSIONS AND TOLERANCES PER ANSI Y14.5M
 2. ALL DIMENSIONS ARE IN MILLIMETERS.
 3. TOLERANCES :
 .XX ± 0.254
 .XXX ± 0.127
 ANGLES $\pm 3^\circ$

ITEM	PART NO.	PART NAME	REMARK	Q'TY
ALPHA CO.,LTD.			CSTM'R'S PART NO.	
	MATERIAL		NAME	QSZ49x49
SCALE	APPR & CHCK	PART NO. & DWG NO.		REV
1 : 1	Y.SUZUKI	S001ZB7K		
DATE	DSGN & DWG	RDCTN:	LOFF:	
JAN 14 2011	Y.SUZUKI			