

ALPHA

Active Heat Sink with Mounting Tabs

FSR40

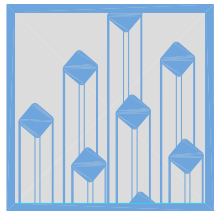

DIM

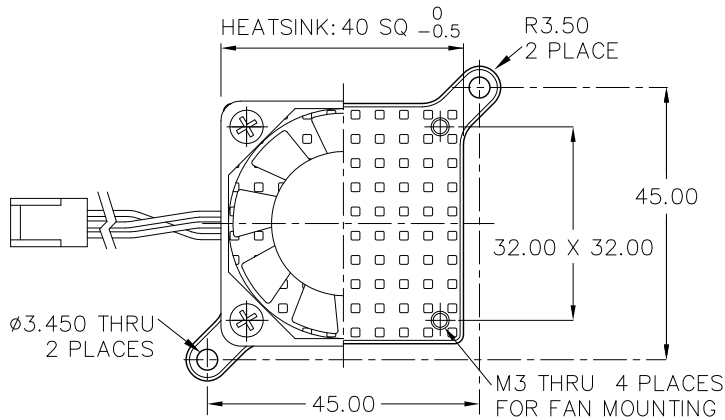

- HEAT SINK
MATERIAL : A 6063
FINISH : BLACK ANODIZE
- FAN / M42
SANYO DENKI 109P0412H901
40 SQ +1.0/-0
- SCREW
PAN HEAD M3
STEEL ZINC / CHROMATE (Cr3+)

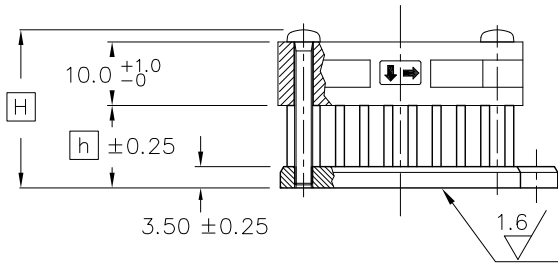

MODEL	HEIGHT		WEIGHT (grams)
	[H]	[h]	
FSR40-8M42	(20.5)	8.0	42.3
FSR40-15M42	(27.5)	15.0	47.0

DIMENSIONS : mm

DATA



FSR40-8M42

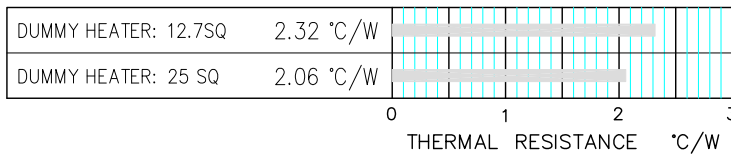

FSR40-15M42

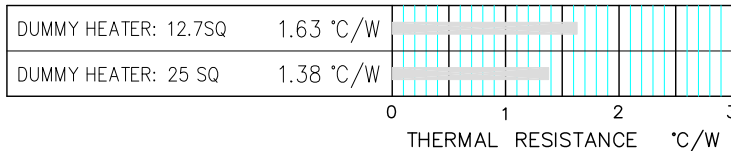

- TESTING SPECIFICATIONS
DUMMY HEATER SIZE: 12.7SQ & 25SQ
- BASED ON ALPHA'S STANDARD TEST PROCEDURE.
REFER TO TECHNICAL INFORMATION.

REF



PCB HOLE LAYOUT

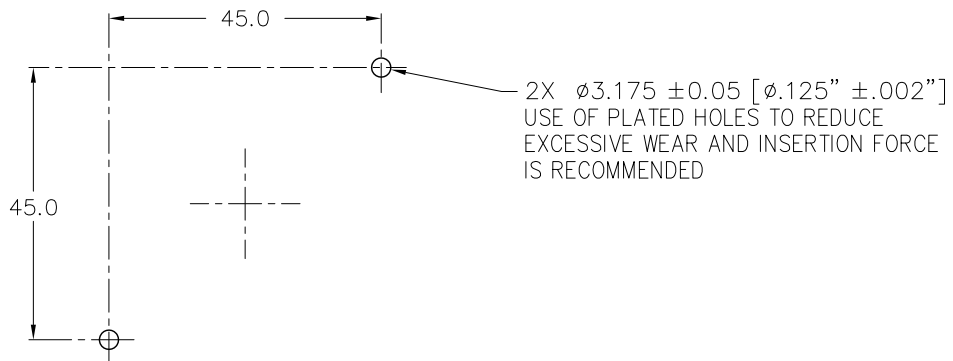

Alpha Company Ltd.

256-1 UEDA, NUMAZU-CITY SHIZUOKA-PREF., JAPAN
 PHONE +81(55)966 0789
 FAX +81(55)966 9192
 E mail : alpha@micforg.co.jp
 URL : http://www.micforg.co.jp

Alpha Novatech, Inc. - a subsidiary of Alpha Company.

473 Sapena Ct. #12 Santa Clara, CA 95054 USA
 PHONE +1(408)567-8082
 FAX +1(408)567-8053
 E mail : sales@alphanovatech.com
 URL : http://www.alphanovatech.com